



**USER MANUAL
AV ALPHA**

**AKILA d.o.o
2023**

ATTENTION:

Read the complete user manual before using the rifle. Your dealer will be happy to answer any questions you may have. Ensure you are completely familiar with its operation before putting it into service. We offer technical instruction courses for law enforcement customers.

Your rifle features a switch barrel system. When changing the calibre, always make sure you are using the right barrel, bolt head and magazine. Always make sure the rifle is unloaded and that the magazine is not inserted into the rifle.



CONTENTS

1.	INTRODUCTION	4
2.	SYMBOLS USED	4
3.	FIREARMS HANDLING RULES	4
4.	LIABILITY	5
5.	RIFLE GENERAL VIEW	5
6.	DISASSEMBLY	6
	6.1 REMOVAL OF THE BOLT	6
	6.2 UNLOCK THE BOLT	6
	6.3 CHANGING THE BOLT HEAD	6
	6.4. REMOVE THE MAGAZINE	7
	6.5. REMOVAL OF THE BARREL	7
	6.6. REMOVAL OF THE FOREEND	7
7.	ASSEMBLY	8
	7.1 ASSEMBLE BOLT	8
	7.2 ASSEMBLE BARREL WITH ACTION	8
	7.3 CALIBRE CHANGE, IDENTIFYING CALIBRE	8
	7.4 ASSEMBLE ACTION WITH STOCK	8
	7.5 MOUNT SCOPE MOUNTS ON PICATINNY-RAIL	9
	7.6 SCOPE MOUNTS	9
	7.7 LOAD MAGAZINE	10
8.	FUNCTION OF THE RIFLE	10
	8.1 3-POSITION SAFETY	10
	8.1.1 SAFE POSITION	11
	8.1.2 MIDDLE POSITION	11
	8.1.3 FIRING POSITION	11
	8.1.4 OPEN BOLT	11
	8.2 LOADING, SHOOTING AND REPEATING	12
	8.3 UNLOADING	12
9	IMPLEMENTING ADJUSTMENTS	12
	9.1 TRIGGER	12
	9.2 WINTER TRIGGER GUARD	13
10.	FOLDING STOCK	13
	10.1 FOLDING	13
	10.2 UNFOLDING	14
11.	BUTTSTOCK ADJUSTMENT	14
	11.1 CHEEKPIECE ADJUSTMENT	14
	11.1.1 CHEEKPIECE HEIGHT ADJUSTMENT	14
	11.1.2 CHEEKPIECE SIDEWAYS ADJUSTMENT	15
	11.2 BUTTSTOCK LENGTH ADJUSTMENT	15
	11.3 RECOIL PAD HEIGHT ADJUSTMENT	16
	11.4 MONOPOD ADJUSTMENT	16
	11.5 REMOVING THE BUTTSTOCK	17
	11.6 CHANGING THE BUTTSTOCK FOLDING DIRECTION	18
	11.7 INSTALLING AN AFTERMARKET BUTTSTOCK	19
12.	ACCESSORIES	20
13.	INTERCHANGEABLE FURNITURE	20
14.	STOCK CARE AND CLEANING	22
15.	TECHNICAL CHARACTERISTICS	23
16.	CARE AND MAINTENANCE	24
	16.1 BARREL	24
	16.2 METAL PARTS	24
	16.3 OPTICS	24
	16.4 MAINTENANCE	24
	16.5 TECHNICAL TRAINING COURSES	24
17.	STORAGE	25
18.	SUPPLY SET	25
19.	MUZZLE BRAKE	25
20.	ADDITIONAL INFORMATION	25
21.	LIMITED FACTORY WARRANTY	26
22	NOTES	27



1. INTRODUCTION

Thank you for choosing the AKILA This user manual contains the description of the rifle design, operation instructions and information necessary to safely operate and service the rifle.

Before using the product, please study the user manual thoroughly. If you have questions, please contact your dealer or AKILA representatives.

Your AV ALPHA Bolt Action rifle differs from other bolt-action rifles in the special features of its construction.

Always bear in mind the need for care in handling weapons as well as the legal requirements.

2. SYMBOLS USED

- ▶ - describes the required action
- ✓ - describes the correct result of the fulfilled action
- ! - describes the safety or precaution instruction



RULE describes certain rules to follow.



ATTENTION describes situations which can result in a minor injury or material damage to the product.

3. FIREARMS HANDLING RULES

- Ensure that the gun and ammunition never fall into unauthorized hands;
- Always store the gun and ammunition separately, under lock and key, away from unauthorized access;
- Observe the applicable legal regulations for the storage and use of guns and ammunition;
- Familiarise yourself thoroughly with the operation of your gun and practice all adjustments and functions with an unloaded gun before using it;
- Regard every rifle as loaded and cocked, unless you have established the contrary by opening the bolt and examining chamber and barrel. An unloaded gun should be handled like a loaded gun;
- Always point the muzzle in a safe direction where is no danger to people or property;
- Before loading ensure that the barrel is free, and thereafter make certain that no foreign bodies (e.g. Water, snow, ice, earth) can get in;
- Only use undamaged CIP certified ammunition, with clearly the right calibre for the rifle. Faultily reloaded ammunition can damage your gun and lead to serious injuries;
- Only load your weapon directly before its use;
- Cock your rifle (or release the safety catch) only when you are ready to fire. When cocking (releasing the safety catch) keep the barrel pointing in a safe direction;
- Before each shot check the area in front of and behind your target;
- Only point your gun towards a target that you have clearly recognised;
- Only put your finger on the trigger when you intend to fire;
- If a cartridge does not fire, wait 60 seconds before opening the bolt, in order to avoid the danger of a delayed ignition;
- When shooting, you, and people in the area, should wear ear protection (earplugs) and suitable shooting goggles;
- Your product has been constructed / designed for the use of org. or certified accessories of the AKILA company. Non-certified components may cause damage or accidents

4. LIABILITY

"AKILA" d.o.o shall not be liable and shall not consider claims related to any damage caused by the following reasons:

- Failure to follow instructions contained in this Instruction Manual;
- Servicing and repairing product outside authorized workshops;
- Use of non-original parts (not manufactured by "AKILA" d.o.o. or original rifle manufacturer);
- Improper handling or care;
- Unauthorized change in the design of parts and components;
- Damage during transportation or mishandling.

5. RIFLE GENERAL VIEW

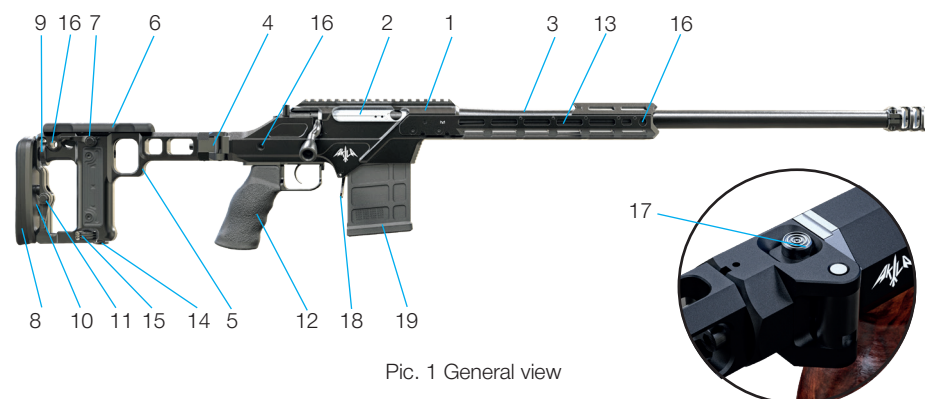

Pic. 1 General view

DESIGNATION OF THE RIFLE

1. RECEIVER
2. BOLT
3. BARREL
4. FOLDING MECHANISM
5. BUTTSTOCK
6. CHEEKPIECE
7. CHEEKPIECE ADJUSTMENT LEVER (HEIGHT)
8. RECOIL PAD
9. BUTTSTOCK ADJUSTMENT WHEEL (LENGTH)
10. RECOIL PAD ADJUSTMENT LEVER (HEIGHT)
11. BUTTSTOCK ADJUSTMENT LEVER
12. GRIP
13. FOREEND
14. MONOPOD
15. MONOPOD ADJUSTMENT WHEEL
16. QD SLING MOUNT
17. FOLDING MECHANISM BUTTON
18. MAGAZINE CATCH
19. MAGAZINE

6. DISASSEMBLY

6.1. REMOVAL OF THE BOLT



Pic. 2 Removal of the Bolt

Unlock the chamber by turning it 60° with the bolt handle, pull it backwards and at the same time press the left-hand lock holder lever. In any case before the chamber is in the rear position. First, the bolt handle is grasped and then opened in one quick movement. This allows the bolt to be easily pulled out of the action. When reinserting the bolt into the action, center it carefully and insert it with a slight turn to the right.

ATTENTION
DON'T USE ANY FORCE!

6.2. UNLOCK THE BOLT

To unlock the bolt, bring the safety lever in the middle position.

6.3. CHANGING THE BOLT HEAD

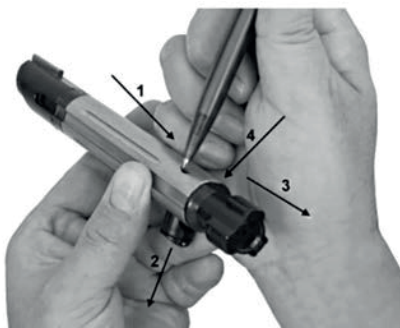

Pic.3 Changing the bolt head.

Remove the bolt from the action. Take the bolt and press the cross bolt out of the bolt with your fingernail, key, ballpoint pen, etc.. (1, 2) and remove it.

The bolt head can now be easily removed to the front (3). A new bolt head can be inserted from the front. It is important that the flats (4) match. The cross bolt is inserted for locking.



Pic. 4 Bolt head

6.4. REMOVE THE MAGAZINE



Pic. 5 REMOVE THE MAGAZINE

The magazine can be removed by pressing the magazine catch in the front of the trigger guard. The magazine is inserted vertically into the magazine, until the lever locks automatically.

6.5. REMOVAL OF THE BARREL



Pic. 6 REMOVAL OF THE BARREL

Loosen the 2 cylinder head screws (TX30) on the left side of the action. As soon as these are loosened (approx. 1 turn), the barrel can be pulled out of the action.

6.6. REMOVAL OF THE FOREEND



Pic. 7 Removal of the foreend

Loosen the 4 countersunk screws (M5x8) on the left and right side of the action. Once these are loosened and completely removed, the foreend can be disassembled.

7. ASSEMBLY

7.1. ASSEMBLE BOLT

When assembling and disassembling the bolt, note that the safety is in the middle position. (safe position, bolt lock not active).

7.2. ASSEMBLE BARREL WITH ACTION



Pic. 8 Assemble Barrel with Action

Push the barrel into the action from the front. Make sure that the index slot is at the top. Due to the tight tolerances, the barrel must match exactly with the action. When the barrel is in the rearmost position, insert the bolt and lock, this will ensure that the barrel is in the correct position.

Then tighten the side clamping screws again with 10 Nm.

⚠ ATTENTION
BE SURE THAT THE BOLT IS REMOVED WHEN REASSEMBLING AND THE CALIBER OF THE BOLT, BARREL AND MAGAZINE MATCH.

7.3. CALIBRE CHANGE, IDENTIFYING CALIBRE

Be absolutely sure that the caliber of the barrel, bolt head and magazine match. You can recognize the caliber of the barrel by the labeling located on the right side of the barrel. The caliber of the magazine is marked on the side. You can recognize the bolt size by the engraving e.g. ST (Standard) on the bolt head. Use the caliber group table. Only use a combination of components that clearly indicate that they belong together.

7.4. ASSEMBLE ACTION WITH STOCK

Take the bolt with your right hand and press the front edge of the bolt holder tightly against the stock. Push the lock into the chamber at the bolt handle. The bolt can be pushed forward until the bolt handle can be turned downward by 60°. The rifle is not locked until the bolt handle is in the lowest position. If the bolt can't be fully inserted into the bolt, check whether the bolt is correctly assembled (Flat points of bolt body and bolt head must be flush!) or the barrel is correctly inserted.

👉 RULE
• DON'T USE FORCE!

7.5. MOUNT SCOPE MOUNTS ON PICATINNY-RAIL



Pic. 9 MOUNT SCOPE MOUNTS ON PICATINNY-RAIL

Your AV ALPHA comes with a Mil Std. 1913 (Picatinny-rail), which has a tilt of 0 MOA. In order to make use of the large adjusting range of modern scopes of 36 mrad (124 MOA, or 360 cm / 100 m) for long range shooting it is necessary to mount the scope tilted. Ideally the tilt of your mount should be half or less of the adjusting range of the scope used (max. 3 mrad, or ca. 10 MOA less).

Place the scope mount with the loosened screws on the Picatinny rail, with the screw heads protruding at the left side of the mount in firing direction. Make sure before tightening the screws (TX25), the scope mounts recoil lug has contact with the Picatinny rail on the face side to prevent it from sliding forward under recoil when firing. Then tighten the screws from the front to the back with 5-6 Nm according to the instruction on the Picatinny base.

7.6. SCOPE MOUNTS

Please follow following points in order to get the best performance in terms of precision and recoil durability.

- 1.) Fix your rifle in a vice exactly horizontally by placing a mechanic's level on the Picatinny rail.
- 2.) Install scope mount according to description.
- 3.) Remove upper part of the scope mount rings (only necessary for scope mounts with diam 30 mm. Check horizontal alignment of the scope mount by placing the mechanic's level on the mount (An aberration of up to 2° can be tolerated).
- 4.) Place scope in the mount so that the turret is arranged right between the rings. Note that the scope mount has some initial tension in order hold the scope firmly in place when installed.
- 5.) Place upper ring parts and hand-tighten 4 Torx screws (TX20) in a way that the clearance between upper and lower rings is about the same on each ring and side.
- 6.) At this point you will note that it is hard to roll the scope in the mount along its longitudinal axis.
- 7.) Place a perpendicular in a distance of 5-6 m in front of the scope and align the vertical line of your scopes Reticle parallel to the perpendicular.
- 8.) Start to slightly tighten the screws on your scope rings crosswise while controlling the alignment of your scope with the perpendicular. (Tighten screws evenly!).
- 9.) Fully tighten screws by using a torque wrench with 2.5 Nm.
- 10.) Check the uniformity of the clearance between upper and lower ring on the scope mount.
- 11.) The scope is mounted successfully when the reticle is still aligned to the perpendicular. Check eye relief of your scope (depending on make and model 60 – 90 mm). Change position of scope if necessary.

Note: It is not necessary to use any kind of glue during this operation.

7.7. LOAD MAGAZINE

Make sure that the magazine corresponds to the calibre chosen. The calibre is marked on the magazine. The magazine is placed in the magazine slot. Make sure that the magazine latches.



Pic. 10 Load Magazine

In calibers with low shoulder seating, it is important that the rim of the cartridge be pushed all the way to the rear and pressed into the groove at the rear of the magazine so that the base of the cartridge rests against the rear of the magazine. If the cartridge is not in contact, jamming is to be expected. The easiest way is to push the cartridge into the magazine from the front. Then press down slightly on the bullet, pushing it all the way back until the groove can be inserted into the groove of the magazine.

8. FUNCTION OF THE RIFLE

8.1. 3-POSITION SAFETY

The safety mechanism of the ALPHA 3 is based on the secured firing pin nut. The A3 is equipped with a 3-position safety. When repeating, the weapon remains cocked or is cocked again. In the rear, secured position (two white dots visible), the bolt handle is simultaneously locked against unintentional opening of the action.

⚠ ATTENTION Never reach into the trigger when unlocking and securing. This would trigger the shot.

8.1.1 SAFE POSITION



Pic.11 Safe position

In the rear, locked position (two white dots). The safety lever is facing away from the bolt handle and is near the firing pin nut, facing the shooter. The gun is not ready to fire, the action is locked.

8.1.2 MIDDLE POSITION



Pic.12 Middle position

Use your thumb and forefinger to push the safety lever to the center position (a white dot). The gun is in the middle position where the bolt can be opened in the secured state.

8.1.3 FIRING POSITION



Pic. 13 Firing position

Use your thumb and forefinger to push the safety lever to the unlocked position (red dot). The safety is released and the gun is ready to fire. In the unlocked position, the safety lever faces the bolt handle.

⚠ ATTENTION Danger to life! It is essential to observe the general safety rules.

8.1.4 OPEN BOLT

The ALPHA 3 can be opened, both cocked and decocked, in the secured state of the center position, and in the unsecured state, the unsecured position (red dot).

⚠ ATTENTION Please ensure that the safety catch is securely engaged in the desired position and is not in an intermediate position.

8.2. LOADING, SHOOTING AND REPEATING

Insert the filled magazine into the gun from below. Make sure that the magazine holders also engage in the magazine. If the rifle is equipped with the optionally available safety cocking mechanism, push the cocking knob forward a few millimeters to open the chamber so that a cartridge can be repetition from the magazine into the chamber. This means the gun is loaded, not cocked and therefore safe. It is not cocked until just before the shot is fired by pushing the cocking knob forward. Once the rifle is cocked, it can be immediately repeated at any time. The rifle remains cocked.

When loading the magazine make sure that the bottom of the cartridge in the magazine is against the rear.

⚠ ATTENTION When loading and unloading the rifle make sure that the barrel is pointed in a safe direction. Load by enclosing the bolt handle with your hand, pushing it upward and moving it quickly to the rearmost position before moving it forward again quickly and closing it. When repeating, it is also important to make sure that the bolt remains in the rearmost position for a short time so that a new cartridge can be pushed up from the magazine.

8.3. UNLOADING

Pay attention that the gun is fully unloaded after the use. Do not only remove the magazine, but also make a visual check that the chamber is empty. When it is dark, check with a finger if necessary. In this way accidents can be avoided. After you have satisfied that there is no cartridge left in the gun or in the magazine, you can decock the rifle. To do this, open the chamber and close it again while pulling the trigger to close it.

9. IMPLEMENTING ADJUSTMENTS

9.1. TRIGGER

The AV ALPHA comes with a Two-stage Match trigger (MD) (various versions) as standard. The trigger weight is adjusted as light as possible to what still is considered safe by international norm. Adjusting the trigger must only be done by AKILA authorized personal to avoid accidents.

Adjustments / Features:

- Many adjustment possibilities (sensitivity, first stage trigger travel, pressure point)
- 3 different trigger blades (straight / bent / adjustable trigger shoe)

Optionally, Direct trigger (MF) and Single-set trigger are possible.

9.2. WINTER TRIGGER GUARD



Pic. 14 Firing position

The rifle is equipped with a winter trigger guard. Through this trigger guard the shooting with hand gloves is easier. The guard can be folded to the right or on the left side by pressing the button at the end of the pistol grip. Then the guard locks in this position.

10. FOLDING STOCK

10.1 FOLDING

1

- ▶ Press the buttstock catch button 16 and simultaneously pull the buttstock 3 (in the direction indicated by the arrow).

✓ The butt stock is released.

2

- ▶ Turn the buttstock 3 in the direction indicated by the arrow until it gets fixed with the catch.

✓ The butt stock is folded.

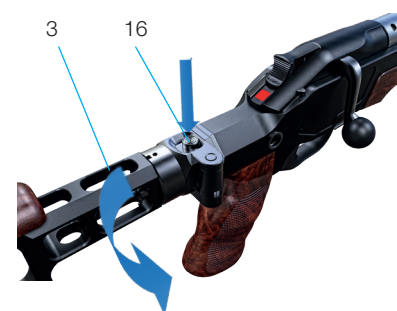

Pic. 15 Press the button, fold the buttstock.



Pic. 16 The butt stock is folded.

10.2 UNFOLDING

▶ Press the buttstock catch button 16 and simultaneously pull the buttstock 3 (in the direction indicated by the arrow).

✓ The buttstock is released.

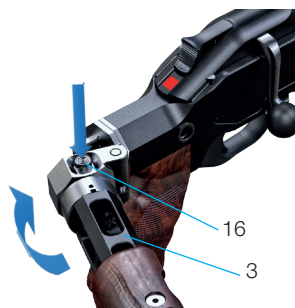

Pic.17 Unfold the buttstock.

11 BUTTSTOCK ADJUSTMENT

11.1 CHEEKPIECE ADJUSTMENT

11.1.1 CHEEKPIECE HEIGHT ADJUSTMENT

- ▶ Turn the lever 5 counter-clockwise and unlock the cheekpiece 4;
- ▶ Pull the cheekpiece 4 up or down to the desired position;
- ▶ Lock the position of the cheekpiece 4 by tightening the lever 5 clockwise.

✓ The cheek piece is adjusted.

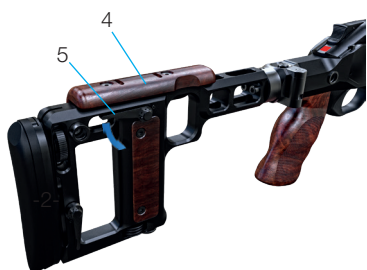

Pic. 18 Cheekpiece before adjustment (HEIGHT).



Pic. 19 Cheekpiece after adjustment (HEIGHT).

11.1.2 CHEEKPIECE SIDEWAYS ADJUSTMENT

- ▶ Fix the cheekpiece 4 as in paragraph 13.1.1;
- ▶ Using the 4 mm allen key loosen the screws that fix the cheekpiece 4;
- ▶ Adjust the cheekpiece 4 to the left or to the right;
- ▶ Using the 4 mm allen key tighten the screws to fix the cheekpiece 4.

Tightening torque 6-6,5 N*m (0,6-0,65 kg*m);

✓ The cheekpiece is adjusted.

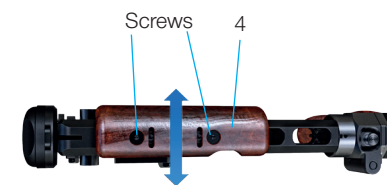

Pic. 20 Cheekpiece after adjustment (SIDEWAYS).

11.2 BUTTSTOCK LENGTH ADJUSTMENT

- ▶ Turn the lever 9 counter-clockwise to loosen the recoil pad 6 length adjustment;
- ▶ Turning the wheel 7 changes the position of the recoil pad 6 adjusting the buttstock length;
 - One wheel 7 turn adjusts the recoil pad 6 position by 1,25mm;
 - Recoil pad 6 adjustment travel is 40 mm.

▶ To lock the recoil pad position turn the tightening lever 9 clockwise.

✓ The recoil pad is adjusted.



Pic. 21 Recoil pad 6 adjusted (length).

11.3 RECOIL PAD HEIGHT ADJUSTMENT

- ▶ Turn the fixing lever 8 counter-clockwise to release the recoil pad 6 height adjustment;
 - ▶ Pull up or down the recoil pad 6 to the desired position;
 - ▶ Lock the recoil pad 6 position by tightening the lever 8 clockwise.
- ✓ The recoil pad is adjusted.

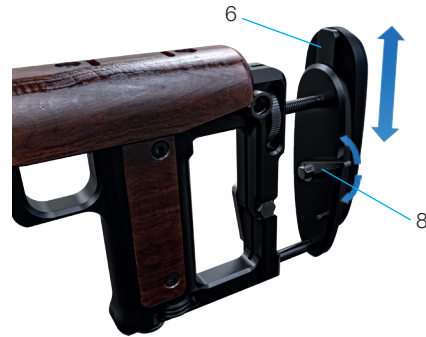

Pic. 22 Recoil pad height adjustment .

11.4 MONOPOD ADJUSTMENT

- ▶ Press the wheel 14 in the direction indicated by the arrow for quick monopod 13 adjustment;
 - ▶ Turn the wheel 14 for fine monopod 13 adjustment.
- ✓ The monopod 13 is adjusted.



Pic. 23 Monopod adjustment.

11.5 REMOVING THE BUTTSTOCK

In order to change the folding side or to install a different AR15 style buttstock.

- ▶ Use the 4 mm allen key to loose the screws by 4-5 mm;
 - ▶ Pull the buttstock 3 back in the direction indicated by the arrow;
 - ▶ Rotate the buttstock 3 counterclockwise until it is removed.
- ✓ The buttstock is removed.



Pic. 24 Unscrew the screws.

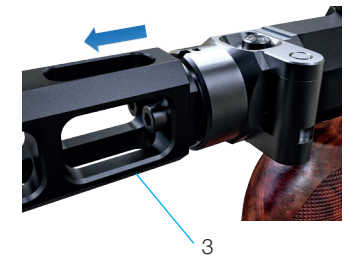

Pic. 25 Unlocked buttstock.



Pic. 26 Remove the buttstock.

- ▶ To install the buttstock repeat steps in reverse order. Tightening torque for screws 6-6,5 N*m (0,6-0,65 kg*m).
- ✓ The buttstock is installed.

11.6 CHANGING THE BUTTSTOCK FOLDING DIRECTION

You may choose the folding side of your AKILA buttstock as well as other AR15 style buttstocks, the folding unit has to be installed upside down to enable the left side buttstock fold. Aftermarket AR15 buttstocks may have to be folded to the opposite side of the bolt grip. AKILA buttstock can be configured to fold both sides covering the bolt grip on left or right handed versions.

1

- ▶ Remove the buttstock (see paragraph 11.5);
 - ▶ Press the folding catch button 16 and simultaneously pull the Foldingstock 2 (in the direction indicated by the arrow);
 - ▶ Use the Torx key  T25 to unscrew the screws that fix the folding unit 2 until it is completely removed.
- ✓ The folding unit 2 is removed.



Pic. 27 Unfold.



Pic. 28 Remove the folding unit.

2

- ▶ Rotate the folding unit 2 by 180 degrees;
 - ▶ Use the Torx key  T25 to install and tighten the screws fixing the folding unit 2. Tightening torque 6-6,5 N*m (0,6-0,65 kg*m);
 - ▶ Close the folding unit 2 until it locks (in the direction indicated by the arrow).
- ✓ The folding direction is changed.





Pic. 29 Folding unit 2 is installed.



Pic. 30 Unfold the folding unit.

11.7 INSTALLING AN AFTERMARKET BUTTSTOCK

The AKILA Chassis System is compatible with most AR15 pattern buttstocks with thread 1 3/16-16 UN. Please read the user manual supplied with the buttstock you have purchased.

- ▶ Use the  1.5 mm allen key to loose the screw counter-clockwise until it is removed (Pic. 20);
 - ▶ Thread the buffertube with the buttstock into the chassis until it stops (Pic. 21). Now, unscrew it back to the point where the buttstock is in a straight position to the chassis. The hole of the M3 screw should be aligned with the groove on the buffer tube (Pic. 22);
 - ▶ Use the  1.5 mm allen key to tighten the screw to fix the buttstock and tighten the castle nut with a special tool. Pic. 23. Using tightening torque 1-1,2 N*m (0,1-0,12 kg*m).
- ✓ The buttstock is installed.



Pic. 31 Remove the screw.



Pic. 32 Install the buttstock.



Pic. 33 The groove on the buffer

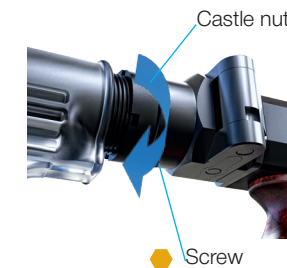

Pic. 34 The buttstock is fixed.

12 ACCESSORIES

Arca Foreend 11 has octagonal cross section with M-LOK™. The 6 o'clock side features a full length ARCA Swiss rail. ARCA Foreend is supplied with a take down AKILA Foreend Upper for top mounted accessories.



Pic. 35 ARCA Swiss rail Foreend.

The stock has 6 QD sling mount 15 points for comfortable sling attachment when the buttstock is folded or unfolded.

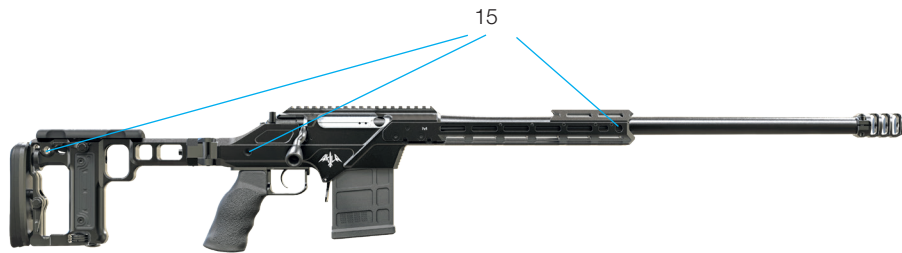

Pic. 36 QD-sling mount left side.

13 INTERCHANGEABLE FURNITURE

1

- ▶ Use the 5 mm allen key to remove the grip;
- ▶ Mount new grip and use the 5 mm allen key for tighten. Tightening torque 2-2,5 N*m (0,2-0,25 kg*m);
- ✓ The grip is changed.

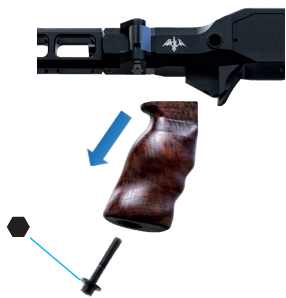

Pic. 37 The grip is removed.

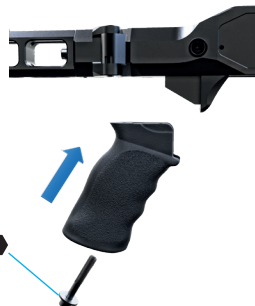

Pic. 38 The grip is installed.

3

Pic. 82 The foregrip cover is installed. Remove the cheekpiece screws covers;

- ▶ Use the 3 mm allen key to remove the cheekpiece;
- ▶ Use the Torx T20 key to unscrew the screws that fix the buttstock panels.
- ✓ The cheekpiece and buttstock panels are removed.



Pic. 39 The cheekpiece and buttstock panels are removed.

ATTENTION Due to different physical storage and use conditions (i.e. humidity, temperature, etc.), wooden parts may slightly change the dimensions, causing difficulties to remove or install the covers.

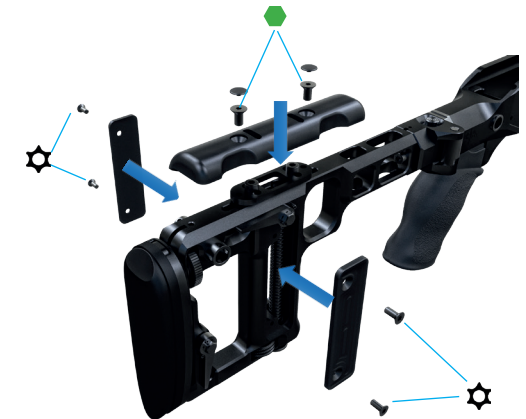

Pic. 40 The cheekpiece and buttstock panels are changed.

14. STOCK CARE AND CLEANING

The AV Alpha has special anti-corrosion coating, anyway it is necessary to monitor the condition of the stock. Corrosion may occur if the chassis is not cleaned after use. Especially if it has deep scratches or any other damage of the coated surface.

The chassis should be regularly maintained at least once a year or more often after heavy use or in severe conditions. Moreover, regular maintenance is recommended if the rifle is stored for a long period. If it is necessary to replace any parts, use only original factory spare parts.

When loosening or tightening screws, make sure that the screwdriver or wrench is of an appropriate size and shape. Improper or low quality tools may damage the screw heads and overall rifle appearance. Use only high quality gun oil that cleans, lubricates and preserves (CLP).

Routine cleaning procedure must be done as follows:

1. In case the stock has been used in wet conditions dry it using compressed air or let it dry in a warm / dry place without any protective cover or drag bag;
2. The wood parts should be treated with special gun wood oil or varnished. It is important to maintain the wooden parts dry after using the chassis and regularly treat with oil. It is recommended to wipe the wood parts with special gun wood oil. Parts made of plastic do not require special care.
3. Wipe the rifle clean from dust, mud etc. and lubricate all metal surfaces with a lubricated rag so that a light film of lubricant remains on the stock.

15. TECHNICAL CHARACTERISTICS

TOTAL RIFLE LENGTH WITH 24" BARREL	1094mm (40,3") / 848mm (30,3")
WEIGHT	4040—4415 g (8.08—8.83 lb)
BARREL LENGTH	560mm/22"
CALIBRE	.308 Win.
TWIST	1:12"
MUZZLE THREAD	M18x1
MAGAZINE	10 RD PMAG® AICS 308 SA
Scope mount MIL-STD 1913	0 MOA

STOCK LENGTH ADJUSTMENT	40 mm (1,6")
CHEEK PIECE HEIGHT ADJUSTMENT	30 mm (1,2")
RECOIL PAD HEIGHT ADJUSTMENT	±31 mm (±1,2")
MONOPOD LENGTH ADJUSTMENT	104mm (4,1")
FOLDING MECHANISM	Folded to the left or to the right rifle side; AR-15 compatible pattern
BUTTSTOCK	With adjustments and integrated monopod; AR-15 compatible pattern
ACCESSORIES INTERFACE	The octagonal handguard features the M-LOK®, ARCA Swiss rain interface
SURFACE TREATMENT	By default black hard anodizing; Cerakote® upon request for extra charge



16. CARE AND MAINTENANCE

Only use products for gun care, which are intended for this purpose.

⚠ ATTENTION When delivering and transporting the rifle, the barrel – especially on the inside – and metal parts of the rifle are covered with a corrosionresistant oil!

All parts of the weapon – especially the inside of the barrel – **MUST** be cleaned before the use. This is the only way to guarantee a safe use of the rifle!

16.1 BARREL

Oil barrel including chamber after firing, before long term storage and after carrying your rifle, especially in wet or humid conditions. Remove oil before firing! We recommend using chemical cleaning to remove residue, especially when firing high power cartridges or solid bullets. We also recommend to clean the barrel every five rounds fired for the first 250 rounds in order to get the maximum accuracy and longevity out of your firearm.

⚠ ATTENTION Follow instructions of gun care products in order to achieve best results and avoid injury or damage on your rifle or optics!

16.2 METAL PARTS

Keep metal parts clean and slightly oiled.

16.3 OPTICS

Maintenance and cleaning are to be executed according to optics maintenance instructions.

16.4 MAINTENANCE

The rifle should be checked in continuous intervals by trained personnel especially by law enforcement users.

⚠ ATTENTION Maintenance of you firearm must be done by trained personnel only!

16.5 TECHNICAL TRAINING COURES

AKILA offers a 2 day-training course for law enforcement users. In this course technical details and required maintenance are explained in-depth.

This course is designated for personnel with professional firearms qualification.

17. STORAGE

Store the AKILA dry in a cabinet with reduced humidity (30-40%), away from heating devices and avoiding high temperature changes. The air must be free from acid, alkaline and other aggressive substances.

18. SUPPLY SET

- Rifle AV ALPHA;
- User manual;
- Tools for assambly.

19. MUZZLE BRAKE

AKILA Muzzle brake with M18x1 thread.

The Muzzle brake is machined from high carbon steel with special nitriding surface treatment that increases surface hardness and enhances core strength and ensure improved wear and corrosion resistance.

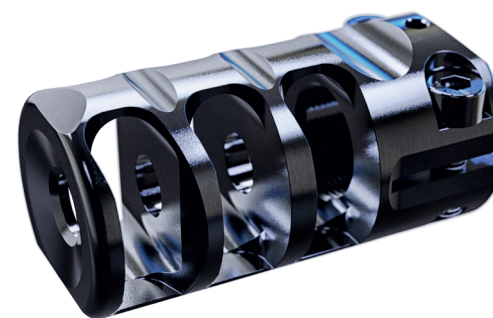

Pic. 41 Muzzle Brake

20. ADDITIONAL INFORMATION

Produced by AKILA
www.akila.ltd | +386 41 794 895 | info@akiladoo.com

21. LIMITED FACTORY WARRANTY

AKILA d.o.o warrants the workmanship and all parts of this product against material or workmanship defects for a period of 3 year from the date of original purchase for use. This warranty shall be effective only if the registration card is fully completed and mailed to AKILA d.o.o. for registration, and applies only to the original purchaser.

This warranty is null and void if the unit and or its components therein have been damaged or tampered with by improper handling, use or unauthorized repair. In all cases of damage during shipment for repair, a claim must be filed with the shipping carrier by the purchaser, and not with AKILA d.o.o. In all events the manufacturers agree to repair or replace the defective parts, but never to exceed the purchase price as paid. As this is a limited warranty, AKILA d.o.o.'s liability for consequential and incidental damages is expressly disclaimed and shall not exceed the purchase price paid.

22. NOTES



Pic. 42 AV ALPHA length unfolded andfolded



www.akila.ltd